

## Excalibur Series

Mil-Dtl-38999 Optical Transponder,  
XAUI to 10GBase-SR Applications,  
Multimode, 850nm VCSELS

### Dual Port, Jam Nut

#### FEATURES

- Suitable for 10GBASE-SR/SRL 10G Ethernet applications @ 10.3125Gbps
- Optical fiber link distances up to 300 Meters (50/125µ 2000MHz\*Km MMF)
- Maximum optical channel bit error rate less than  $1 \times 10^{-12}$
- Operating temperature range from  $-40^{\circ}\text{C}$  to  $+70^{\circ}\text{C}$
- Shock, vibration and immersion resistant per Mil-Std-810 and Mil-Std-1344
- Aluminum alloy Mil-Dtl-38999 housings are strong, durable, corrosion resistant and light weight
- Mil-T-29504 compliant optical fiber connector interface
- Connector insert configuration conforms to Mil-Std-1560

#### APPLICATIONS

Excalibur series bulkhead mounted optical transponders enable extremely high speed network communications over long distances in harsh environments.

- 10 Gigabit Ethernet switches and peripherals
- 10 Gigabit Fibre Channel switches and peripherals
- Serial data links
- Video displays

The Mil-Dtl-38999, Series III shell provides a sealed optical interface that is water-tight to Mil-Std-810 / IP67 / NEMA-4x when mated.

The multimode optical fiber interface supports applications where copper cable link distance, bandwidth, weight or bulk make the use of twisted pair, twinax or quadrax copper conductors unacceptable.



Dual Port XAUI to 10GBase-SR Transponder

#### DESCRIPTION

Excalibur series optical fiber transponders consist of optoelectronic transmitter and receiver functions integrated into a bulkhead mounted Mil-Dtl-38999, Series III receptacle connector along with the 10Gbps / XAUI SerDes functions. The optical transmitters are 850nm VCSEL lasers.

The optical receivers consist of PIN and preamplifier assemblies and limiting post-amplifiers. The XAUI electrical interface to the Excalibur series optical fiber transponders is a Samtec controlled impedance connector enabling interface to a ribbon twinax cable or flexible printed circuit assembly.

Excalibur series optical fiber transponders are vibration isolated, environmentally hardened components designed for use in harsh environment applications.

#### ORDERING INFORMATION

Application	Part Number
XAUI to 10GBase-SR	E38J-4SCK-EF

See Appendix A2 for more part number options

E38J-4SCK-EF-DS - October 11, 2011

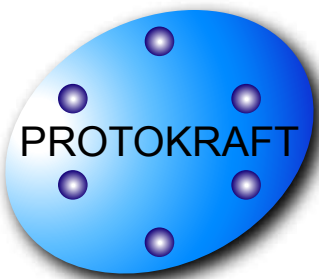

## Facilitating Secure Communications in Harsh Environments

Dual Port Excalibur Series MIL-DTL-38999 Optical Transponder,  
10GBase-SR / XAUI Applications, Multimode, 850nm VCSELs

### ABSOLUTE MAXIMUM RATINGS

Absolute maximum limits mean that no catastrophic damage will occur if the product is subjected to these ratings for short periods, provided each limiting parameter is in isolation and all other parameters have values within the performance specification. It should not be assumed that limiting values of more than one parameter can be applied to the product at the same time.

Parameter	Symbol	Minimum	Typical	Maximum	Unit
Storage Temperature	$T_s$	-55		+100	°C
Supply Voltage	$V_{CC}$	-0.5		+6.0	V

### RECOMMENDED OPERATING CONDITIONS

Parameter	Symbol	Minimum	Typical	Maximum	Unit
Operating Temperature	$T_A$	-40		+70	°C
Supply Voltage	$V_{CC}$	+4.75		+5.25	V
TX Common Mode Voltage	$V_{CM}$		2.0		V
TX Differential Input Voltage (p-p)	$V_D$	0.25		2.2	V
Power Supply Noise (p-p)	$N_P$			200	mV

### SPECIFICATIONS COMPLIANCE

Requirement	Feature	Condition	Notes
MIL-STD-883	ESD	Class II	2200V
MIL-STD-810	Vibration	3.8g <sup>2</sup> /Hz	43G rms
MIL-STD-810	Shock	40.0g	6-9mS
MIL-STD-810	Immersion	1.0 meter	2.0Hours
MIL-STD-1344	Flame Resistance	Method 1012	30 Seconds
MIL-STD-1344	Damp Heat	10 Cycles	24 Hours
MIL-STD-38999	Mating Durability	500 Cycles	<0.5dB Change
FDA / CDRH / IEC-825-1	Eye Safety	Class 1	No Safety Interlocks Required

### MATERIALS

Item	Detail	Notes
Housing & Shell	Aluminum Alloy	
Housing & Shell Plating	Electroless Nickel	
Insert	Thermoplastic	
Interfacial Seal	Elastomer	
Optical Ferrules	Ceramic	
Printed Circuits	Polyimide / FR-4	

E38J-4SCK-EF-DS - October 11, 2011

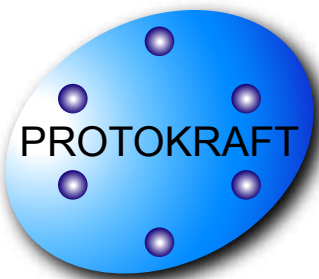

## Facilitating Secure Communications in Harsh Environments

Dual Port Excalibur Series MIL-DTL-38999 Optical Transponder,  
10GBase-SR / XAUI Applications, Multimode, 850nm VCSELs

### OPTICAL TRANSMITTERS $T_A = \text{Operating Temperature Range, } V_{CC} = 4.75V \text{ to } 5.25V$

Parameter	Symbol	Minimum	Typical	Maximum	Unit
Optical Output Power (BER<10 <sup>-12</sup> )	$P_o$	-5.0		-1.0	dBm
Optical Output Wavelength	$\lambda_{OUT}$	840	850	860	nM
Spectral Width	$\Delta\lambda_{RMS}$			0.45	nM
Extinction Ratio	ER	3.0	5.5		dB

### OPTICAL RECEIVERS $T_A = \text{Operating Temperature Range, } V_{CC} = 4.75V \text{ to } 5.25V$

Parameter	Symbol	Minimum	Typical	Maximum	Unit
Optical Sensitivity (BER<10 <sup>-12</sup> )	$P_i$	-11.1		0.0	dBm
Optical Wavelength	$\lambda_{IN}$	840	850	860	nM

### Electrical AC Characteristics $T_A = \text{Operating Temperature Range, } V_{CC} = 4.75V \text{ to } 5.25V$

Parameter	Symbol	Minimum	Typical	Maximum	Unit
XAUI Input/Output Baud Rate - TXLANE[0..3] & RXLANE[0..3]	$R_{XAUIIN/OUT}$		3.125		Gbit/s
Baud Rate Variation	$R_{XAUIVAR}$	-100		100	ppm
Differential Input / Output Impedance	$Z_{XAUIIN/OUT}$	80	100	120	$\Omega$
Input Differential Skew	$t_{SKEWIN}$			75	ps
Output Differential Skew	$t_{SKEWOUT}$			15	ps

### POWER SUPPLY CURRENT $T_A = \text{Operating Temperature Range, } V_{CC} = 4.75V \text{ to } 5.25V$

Parameter	Symbol	Minimum	Typical	Maximum	Unit
Supply Current per Port	$I_{CCT}$		300	400	mA

### OPTICAL LINK DISTANCES

Cable Type	62.5/125 $\mu$ 160MHz*Km	62.5/125 $\mu$ 200MHz*Km	50/125 $\mu$ 400MHz*Km	50/125 $\mu$ 500MHz*Km	50/125 $\mu$ 2000MHz*Km
Maximum Supported Link Distance - Meters	26	33	66	82	300

E38J-4SCK-EF-DS - October 11, 2011

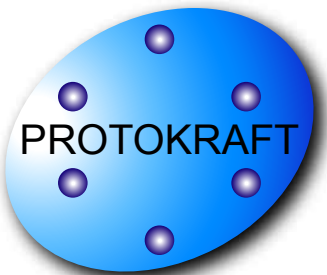

*Facilitating Secure Communications in Harsh Environments*

Dual Port Excalibur Series MIL-DTL-38999 Optical Transponder,  
10GBase-SR / XAUI Applications, Multimode, 850nm VCSELs

**OUTLINE DRAWING**

**Jam Nut Option**

Dimensions are shown as: inches (mm)

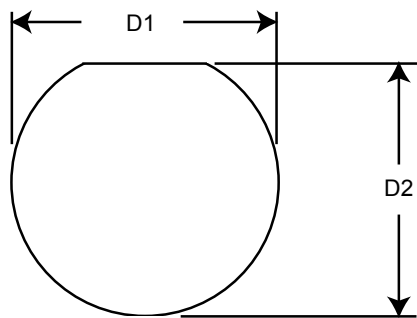
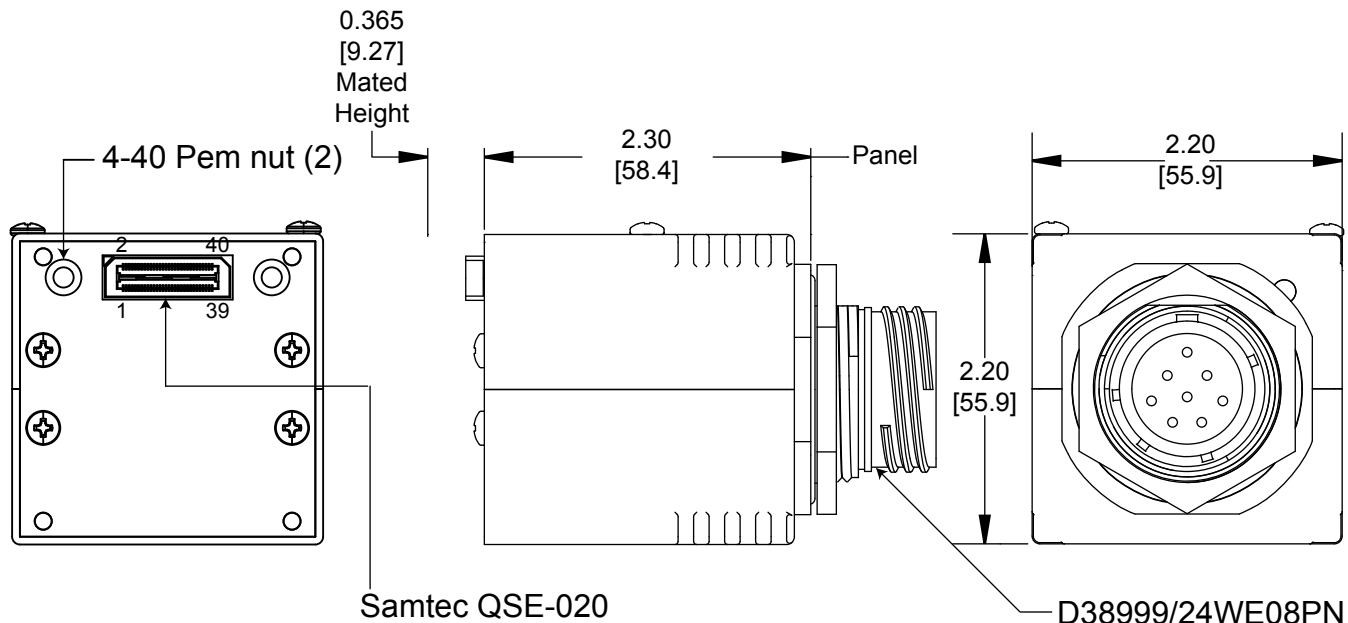

**Panel Cutout Dimensions**

Shell Size Code	Shell Size	D1 Min	D2 Min
E	17	1.260 (32.01)	1.210 (30.73)

E38J-4SCK-EF-DS - October 11, 2011

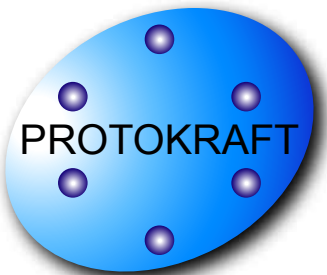

*Facilitating Secure Communications in Harsh Environments*

Dual Port Excalibur Series MIL-DTL-38999 Optical Transponder,  
10GBase-SR / XAUI Applications, Multimode, 850nm VCSELs

**OPTICAL TRANSCEIVER INSERT ARRANGEMENT**

**TOP**  
**Optical Interface**

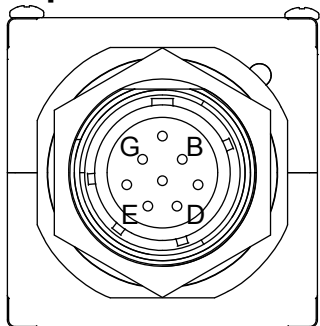

Front face of the optical transponder insert shown, fiber optic cable plug opposite - see Appendix A1 for details

**TOP**  
**Electrical Interface**

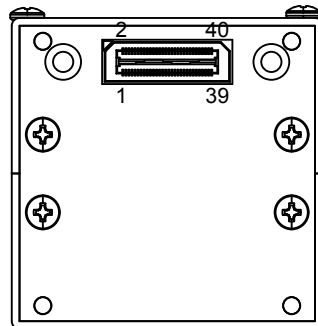

Back face of the optical transponder insert shown - see Electrical Pin Assignment pages for details

**OPTICAL TRANSPONDER PORT ASSIGNMENTS**

PORT NUMBER	TX	RX
0	G	E
1	B	D

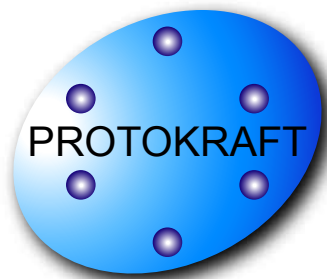

## Facilitating Secure Communications in Harsh Environments

Dual Port Excalibur Series MIL-DTL-38999 Optical Transponder,  
10GBase-SR / XAUI Applications, Multimode, 850nm VCSELs

### ELECTRICAL PIN ASSIGNMENTS

Pin	Symbol	Port	Lane	I/O	+/-	Description	Logic Family
1	XAUI(0)_IN(0)_P	0	0	I	+	XAUI TX Lane 0 +	AC-coupled, Internally biased differential XAUI
2	XAUI(0)_OUT(0)_P	0	0	O	+	XAUI RX Lane 0 +	AC-coupled, Internally biased differential XAUI
3	XAUI(0)_IN(0)_N	0	0	I	-	XAUI TX Lane 0 -	AC-coupled, Internally biased differential XAUI
4	XAUI(0)_OUT(0)_N	0	0	O	-	XAUI RX Lane 0 -	AC-coupled, Internally biased differential XAUI
5	XAUI(0)_IN(1)_P	0	1	I	+	XAUI TX Lane 1 +	AC-coupled, Internally biased differential XAUI
6	XAUI(0)_OUT(1)_P	0	1	O	+	XAUI RX Lane 1 +	AC-coupled, Internally biased differential XAUI
7	XAUI(0)_IN(1)_N	0	1	I	-	XAUI TX Lane 1 -	AC-coupled, Internally biased differential XAUI
8	XAUI(0)_OUT(1)_N	0	1	O	-	XAUI RX Lane 1 -	AC-coupled, Internally biased differential XAUI
9	XAUI(0)_IN(2)_P	0	2	I	+	XAUI TX Lane 2 +	AC-coupled, Internally biased differential XAUI
10	XAUI(0)_OUT(2)_P	0	2	O	+	XAUI RX Lane 2 +	AC-coupled, Internally biased differential XAUI
11	XAUI(0)_IN(2)_N	0	2	I	-	XAUI TX Lane 2 -	AC-coupled, Internally biased differential XAUI
12	XAUI(0)_OUT(2)_N	0	2	O	-	XAUI RX Lane 2 -	AC-coupled, Internally biased differential XAUI
13	XAUI(0)_IN(3)_P	0	3	I	+	XAUI TX Lane 3 +	AC-coupled, Internally biased differential XAUI
14	XAUI(0)_OUT(3)_P	0	3	O	+	XAUI RX Lane 3 +	AC-coupled, Internally biased differential XAUI
15	XAUI(0)_IN(3)_N	0	3	I	-	XAUI TX Lane 3 -	AC-coupled, Internally biased differential XAUI
16	XAUI(0)_OUT(3)_N	0	3	O	-	XAUI RX Lane 3 -	AC-coupled, Internally biased differential XAUI
17	GND	N/A	N/A	N/A	N/A	Isolated Signal Ground	N/A
18	VPX_5VDC	N/A	N/A	I	+	+4.75 to +5.25VDC	N/A
19	GND	N/A	N/A	N/A	N/A	Isolated Signal Ground	N/A
20	VPX_5VDC	N/A	N/A	I	+	+4.75 to +5.25VDC	N/A
21	GND	N/A	N/A	N/A	N/A	Isolated Signal Ground	N/A
22	TX_DIS	0	N/A	I	+	TX_Dis Port 0	Open Drain CMOS, 3.3VDC= TX_OFF / Low=TX_ON
23	GND	N/A	N/A	N/A	N/A	Isolated Signal Ground	N/A
24	TX_DIS	1	N/A	I	+	TX_Dis Port 1	Open Drain CMOS, 3.3VDC= TX_OFF / Low=TX_ON
25	XAUI(1)_IN(0)_P	1	0	I	+	XAUI TX Lane 0 +	AC-coupled, Internally biased differential XAUI
26	XAUI(1)_OUT(0)_P	1	0	O	+	XAUI RX Lane 0 +	AC-coupled, Internally biased differential XAUI
27	XAUI(1)_IN(0)_N	1	0	I	-	XAUI TX Lane 0 -	AC-coupled, Internally biased differential XAUI
28	XAUI(1)_OUT(0)_N	1	0	O	-	XAUI RX Lane 0 -	AC-coupled, Internally biased differential XAUI
29	XAUI(1)_IN(1)_P	1	1	I	+	XAUI TX Lane 1 +	AC-coupled, Internally biased differential XAUI
30	XAUI(1)_OUT(1)_P	1	1	O	+	XAUI RX Lane 1 +	AC-coupled, Internally biased differential XAUI
31	XAUI(1)_IN(1)_N	1	1	I	-	XAUI TX Lane 1 -	AC-coupled, Internally biased differential XAUI
32	XAUI(1)_OUT(1)_N	1	1	O	-	XAUI RX Lane 1 -	AC-coupled, Internally biased differential XAUI
33	XAUI(1)_IN(2)_P	1	2	I	+	XAUI TX Lane 2 +	AC-coupled, Internally biased differential XAUI
34	XAUI(1)_OUT(2)_P	1	2	O	+	XAUI RX Lane 2 +	AC-coupled, Internally biased differential XAUI
35	XAUI(1)_IN(2)_N	1	2	I	-	XAUI TX Lane 2 -	AC-coupled, Internally biased differential XAUI
36	XAUI(1)_OUT(2)_N	1	2	O	-	XAUI RX Lane 2 -	AC-coupled, Internally biased differential XAUI
37	XAUI(1)_IN(3)_P	1	3	I	+	XAUI TX Lane 3 +	AC-coupled, Internally biased differential XAUI
38	XAUI(1)_OUT(3)_P	1	3	O	+	XAUI RX Lane 3 +	AC-coupled, Internally biased differential XAUI
39	XAUI(1)_IN(3)_N	1	3	I	-	XAUI TX Lane 3 -	AC-coupled, Internally biased differential XAUI
40	XAUI(1)_OUT(3)_N	1	3	O	-	XAUI RX Lane 3 -	AC-coupled, Internally biased differential XAUI

E38J-4SCK-EF-DS - October 11, 2011

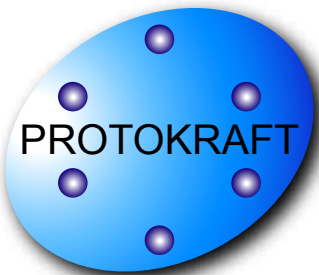

*Facilitating Secure Communications in Harsh Environments*

Dual Port Excalibur Series MIL-DTL-38999 Optical Transponder,  
10GBase-SR / XAUI Applications, Multimode, 850nm VCSELs

**APPENDIX A1**

**MIL-DTL-38999 FIBER OPTIC CABLE PLUG / MIL-T-29504 RECEPTACLE TERMINI**

\*See DSCC or SAE QPL for Approved Suppliers

<http://www.dscclia.mil/programs/qmlqpl/QPLdetail.asp?QPL=38999>

**\*D38999 PLUG - RECEPTACLE INSERT**

**MIL-DTL-38999 CABLE PLUG**

MS PLUG P/N

\*D38999/26WE08SN

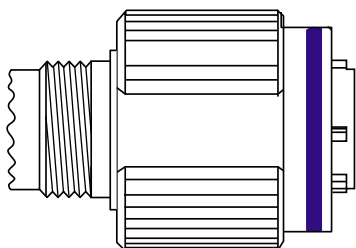

**\*FIBER OPTIC TERMINUS**

**M29504 RECEPTACLE TERMINUS**

RECEPTACLE

\*M29504/05-xxxx\*\*



\*\*defined by fiber optic cable configuration

**\*CABLE PROTECTION CAP**

**D38999/32 PLUG PROTECTION CAP**

MS PLUG CAP P/N

\*D38999/32W17N

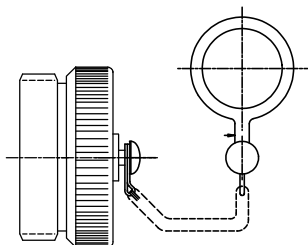

**D38999 PLUG PORT FUNCTIONS**

PORT NUMBER	TX	RX
0	G	E
1	B	D

**\*CABLE BACKSHELL**

**MIL-C-85049 CABLE BACKSHELL**

MS BACKSHELL P/N

\*MS85049/xxxxxx\*\*

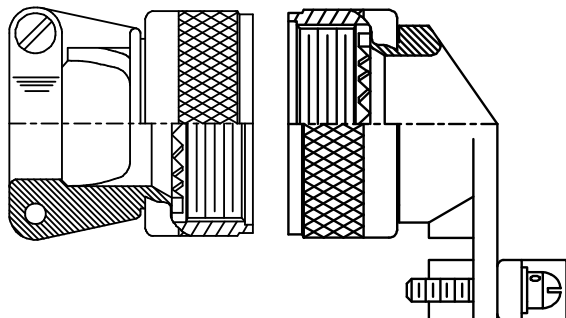

\*\*Straight or angled backshell - defined by application / mounting configuration

E38J-4SCK-EF-DS - October 11, 2011

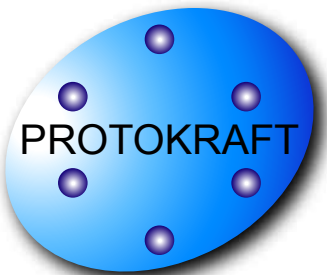

## Facilitating Secure Communications in Harsh Environments

Dual Port Excalibur Series MIL-DTL-38999 Optical Transponder,  
10GBase-SR / XAUI Applications, Multimode, 850nm VCSELs

### APPENDIX A2 PART NUMBER OPTIONS Dual Port, Jam Nut, VCSEL

**E38 J - 4 S C K - E X X**

Product Configuration  
E38= Excalibur Series

Shell Configuration  
J = Jam Nut

# Channels (TX+RX)  
4= 2TX + 2RX

Wavelength  
S= 850nm

Power Supply  
C= +5VDC

Fiber Optic Interface  
K = 10Gbps

Shell Size Code  
E = 17-08

Shell Plating  
F = NI  
W = OD CD / NI  
Z = ZN - NI

Polarization  
(leave blank) \_ = N  
A = A  
B = B  
C = C  
D = D

Other wavelength, mounting and port count options are available.  
Please consult the Protokraft website for alternate configurations.

E38J-4SCK-EF-DS - October 11, 2011