

# Matrix Series

MIL-DTL-38999 Optical Transceiver,  
GbE, FC, ARINC 818 or sFPDP  
Applications, Multimode, 850nm

## 16xTX or 16xRX, Flange Mount

### FEATURES

- Suitable for GbE, Fibre Channel, ARINC 818 and sFPDP applications at up to 5.0Gbps
- Optical fiber link distances up to 550 Meters (50/125µ 2000MHz\*Km MMF)
- Maximum optical channel bit error rate less than  $1 \times 10^{-12}$
- Operating temperature range from -55°C to +85°C
- Shock, vibration and immersion resistant per MIL-STD-810 and Mil-Std-1344
- Aluminum alloy D8999 housings are strong, durable, corrosion resistant and light weight
- M29504 compliant optical fiber connector interface

### APPLICATIONS

Matrix series bulkhead mounted optical transceivers enable extremely high speed network communications over long distances in harsh environments.

- Gigabit Ethernet switches and peripherals
- Fibre Channel switches and peripherals
- Video displays and display drivers
- High speed sensor data links

The MIL-DTL-38999, Series III shell provides a sealed optical interface that is water-tight to Mil-Std-810 / IP67 / NEMA-4x when mated.

The multimode optical fiber interface supports applications where copper cable link distance, bandwidth, weight or bulk make the use of twisted pair, twinax or quadax copper conductors unacceptable.



16xTX or 16xRX lines operating from 0.125 to 5.0Gbps

### DESCRIPTION

Matrix series octal port (16x fiber) optoelectronic transceivers consist of up to 16 total optical transmitter or receiver functions integrated into a bulkhead mounted MIL-DTL-38999, Series III receptacle connector. The optical transmitters are 850nm VCSEL lasers. The transmitter input lines are driven with differential CML signals applied to the transmitter (TX+ and TX-) lines. Dual loop, temperature compensated, VCSEL drivers convert the transmitter input signals to suitable VCSEL bias and modulation currents.

The optical receivers consist of PIN and preamplifier assemblies and limiting post-amplifiers. Outputs from the receivers consist of differential CML data signals on the receiver (RX+ and RX-) lines and single ended CMOS indicator functions on the Loss of Signal (LOS) lines. The receiver data lines are squelched upon LOS assertion, preventing errant data generation when an invalid incoming optical signal is presented to the transceiver.

The electrical interface to the Matrix series optical fiber transceivers is a controlled impedance connector enabling interface to a ribbon coax or twinax cable or flexible printed circuit assembly.

Matrix series octal port optical fiber transceivers are vibration isolated, environmentally hardened components designed for use in harsh environment applications.

- Panel mounted D38999 interface sealed against liquid and solid contaminants
- Shock and vibration resistant

### ORDERING INFORMATION

Application	Part Number
8xTX + 8xRX - Flange	T38F-0808-HW
16xTX - Flange	T38F-1600-HW
16xRX - Flange	T38F-0016-HW

See Appendix A2 for other part number options

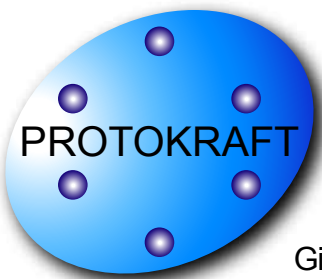

## Facilitating Secure Communications in Harsh Environments

Matrix Series MIL-DTL-38999 Optical Transceiver,  
Gigabit Ethernet, Fibre Channel, ARINC 818 Applications, Multimode, 850nm

### ABSOLUTE MAXIMUM RATINGS

Absolute maximum limits mean that no catastrophic damage will occur if the product is subjected to these ratings for short periods, provided each limiting parameter is in isolation and all other parameters have values within the performance specification. It should not be assumed that limiting values of more than one parameter can be applied to the product at the same time.

Parameter	Symbol	Minimum	Typical	Maximum	Unit
Storage Temperature	$T_s$	-55		+100	°C
Supply Voltage	$V_{CC}$	-0.5		+4.5	V
TX_DIS Input Voltage	$V_i$	-0.5		$V_{CC} + 0.5$	V

### RECOMMENDED OPERATING CONDITIONS

Parameter	Symbol	Minimum	Typical	Maximum	Unit
Operating Temperature	$T_A$	-40		+85	°C
Supply Voltage	$V_{CC}$	+3.135		+3.465	V
TX Common Mode Voltage	$V_{CM}$		2.0		V
TX Differential Input Voltage (p-p)	$V_D$	0.25		2.2	V
Power Supply Noise (p-p)	$N_P$			200	mV

### SPECIFICATIONS COMPLIANCE

Requirement	Feature	Condition	Notes
MIL-STD-883	ESD	Class II	2200V
MIL-STD-810	Vibration	3.8g <sup>2</sup> /Hz	43G rms
MIL-STD-810	Shock	40.0g	6-9mS
MIL-STD-810	Immersion	1.0 meter	2 .0Hours
MIL-STD-1344	Flame Resistance	Method 1012	30 Seconds
MIL-STD-1344	Damp Heat	10 Cycles	24 Hours
MIL-STD-38999	Mating Durability	500 Cycles	<0.5dB Change
FDA / CDRH / IEC-825-1	Eye Safety	Class 1	No Safety Interlocks Required

### MATERIALS

Item	Detail	Notes
Housing & Shell	Aluminum Alloy	
Housing & Shell Plating	Electroless Nickel or OD-CD	
Insert	Thermoplastic	
Interfacial Seal	Elastomer	
Optical Ferrules	Ceramic	
Printed Circuits	Polyimide / FR-4	

T38F-xxxx-HW-DS - April 28, 2012 - Released

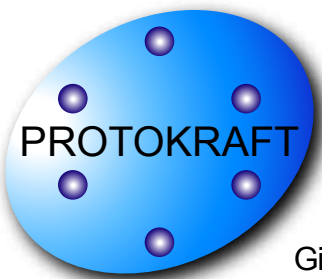

## Facilitating Secure Communications in Harsh Environments

Matrix Series MIL-DTL-38999 Optical Transceiver,  
Gigabit Ethernet, Fibre Channel, ARINC 818 Applications, Multimode, 850nm

### OPTICAL TRANSMITTERS $T_A$ = Operating Temperature Range, $V_{CC}$ = 3.135V to 3.465V

Parameter	Symbol	Minimum	Typical	Maximum	Unit
Optical Output Power (BER<math>10^{-12}</math>, PRBS= 2 <sup>7</sup> -1)	$P_o$	-6.5		-1.0	dBm
Optical Output Wavelength	$\lambda_{OUT}$	830	850	860	nM
Spectral Width	$\Delta\lambda_{RMS}$			0.85	nM
Extinction Ratio	ER	9.0			dB

### OPTICAL RECEIVERS $T_A$ = Operating Temperature Range, $V_{CC}$ = 3.135V to 3.465V

Parameter	Symbol	Minimum	Typical	Maximum	Unit
Optical Sensitivity (BER<math>10^{-12}</math>, ER=9.0) 125Mbps to 1.25Gbps 2.125Gbps 2.5Gbps to 3.19Gbps 3.2Gbps to 5.0Gbps	$P_i$	-17.0 -15.0 -15.0 -14.0		0.0	dBm
Optical Wavelength	$\lambda_{IN}$	830		860	nM

### POWER SUPPLY CURRENT $T_A$ = Operating Temperature Range, $V_{CC}$ = 3.135V to 3.465V

Parameter	Symbol	Minimum	Typical	Maximum	Unit
Supply Current per each element	$I_{CCT}$		90	100	mA

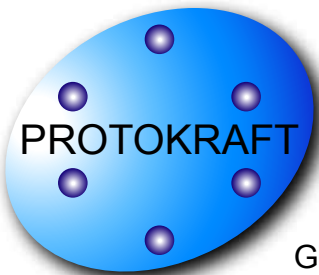

## Facilitating Secure Communications in Harsh Environments

Matrix Series MIL-DTL-38999 Optical Transceiver,  
Gigabit Ethernet, Fibre Channel, ARINC 818 Applications, Multimode, 850nm

### OUTLINE DRAWING

Dimensions are shown as: inches (mm)

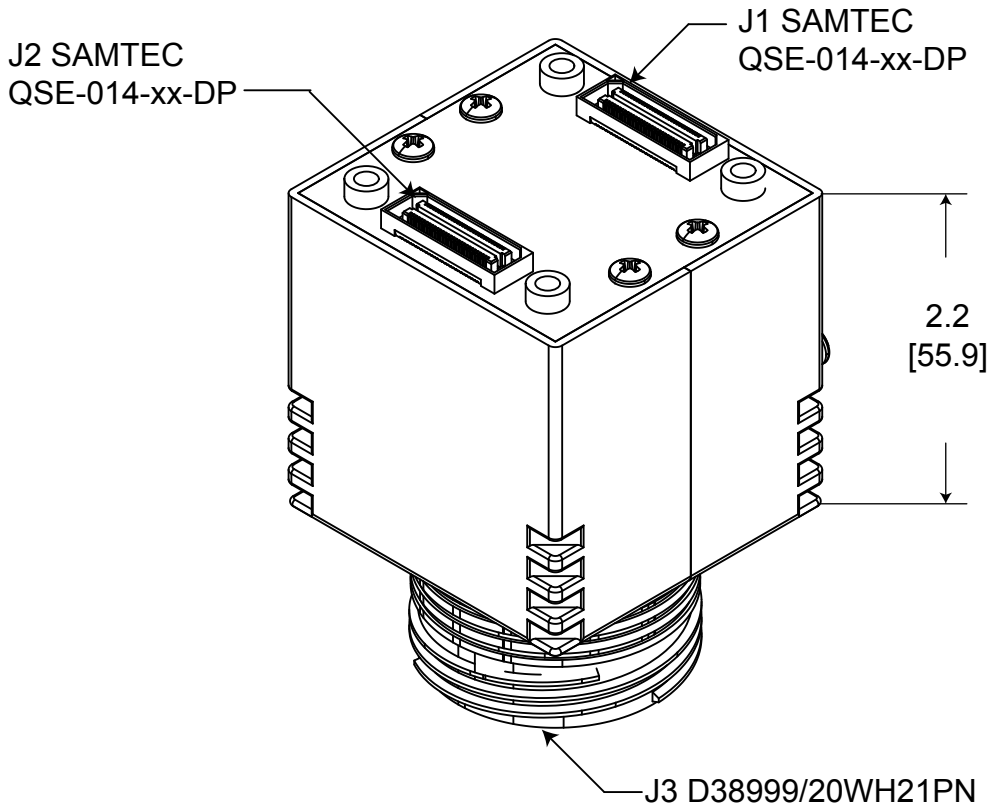
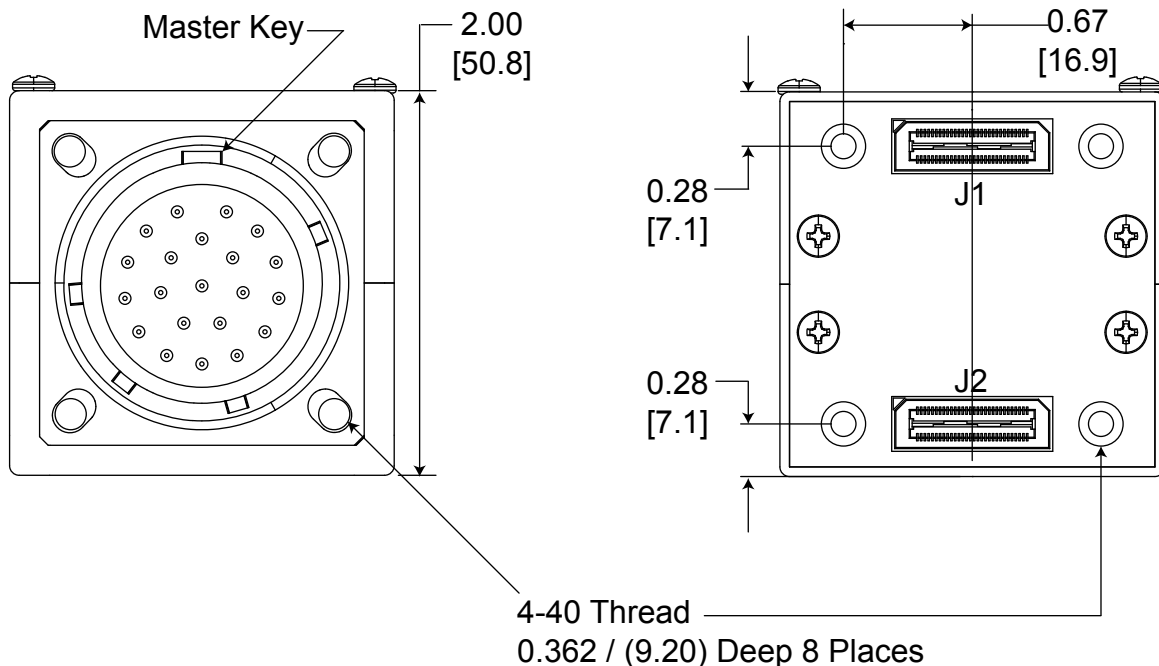

T38F-xxxx-HW-DS - April 28, 2012 - Released

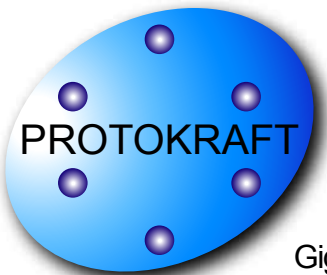

## Facilitating Secure Communications in Harsh Environments

Matrix Series MIL-DTL-38999 Optical Transceiver,  
Gigabit Ethernet, Fibre Channel, ARINC 818 Applications, Multimode, 850nm

### PANEL MOUNTING REQUIREMENTS

Dimensions are shown as: inches (mm)

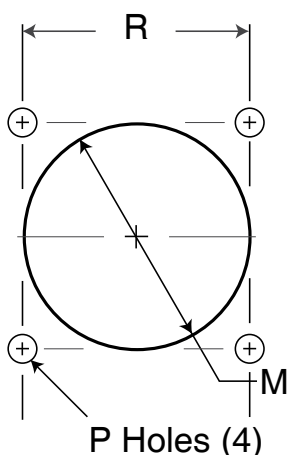
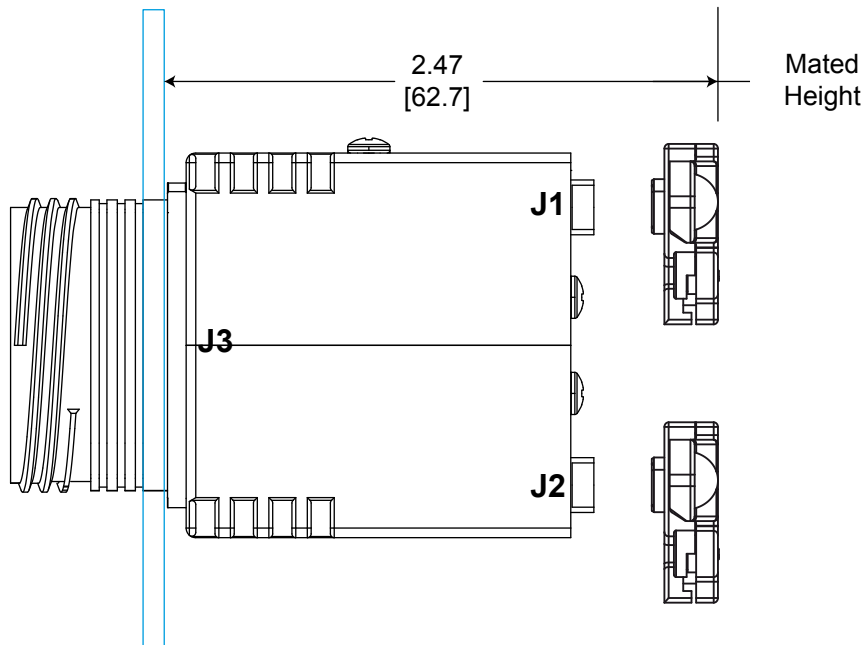

### Panel Cutout Dimensions Rear Panel Mounting Only

Shell Size Code	Shell Size	M Min	P Holes	R Bsc
H	23	1.547 (39.29)	0.159 (4.0) 0.149 (3.8)	1.375 (34.9)

T38F-xxxx-HW-DS - April 28, 2012 - Released

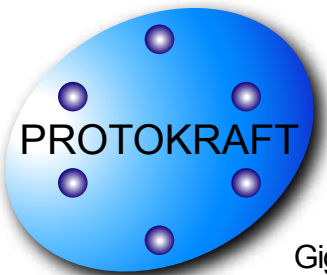

*Facilitating Secure Communications in Harsh Environments*

Matrix Series MIL-DTL-38999 Optical Transceiver,  
Gigabit Ethernet, Fibre Channel, ARINC 818 Applications, Multimode, 850nM

**OPTICAL TRANSCEIVER INSERT ARRANGEMENT**

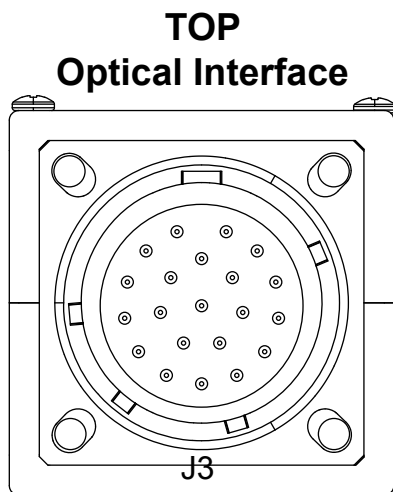

Front face of the optical transceiver insert shown, fiber optic cable plug opposite - see Appendix A1 for details

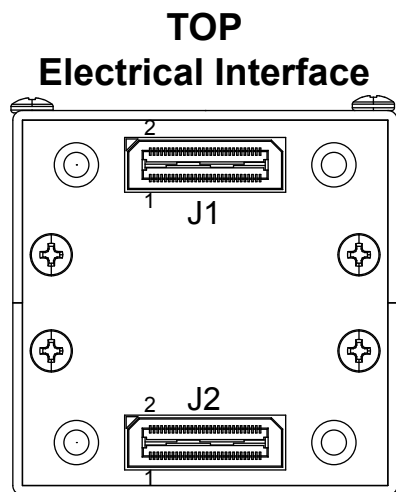

Back face of the optical transceiver shown - see Electrical Pin Assignment pages for details

**OPTICAL TRANSCEIVER PORT ASSIGNMENTS**

Electrical Connector J1 / J2	J3 Optical Pin Assignment
J1	B
	A
	N
	M
	C
	R
	W
	L
J2	D
	S
	V
	K
	E
	F
	H
	J

T38F-xxxx-HW-DS - April 28, 2012 - Released

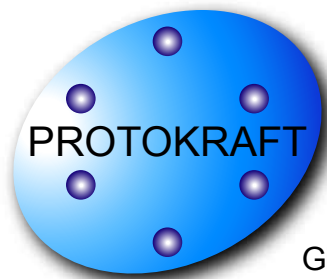

## Facilitating Secure Communications in Harsh Environments

Matrix Series MIL-DTL-38999 Optical Transceiver,  
Gigabit Ethernet, Fibre Channel, ARINC 818 Applications, Multimode, 850nm  
**J1 ELECTRICAL PIN ASSIGNMENTS - 0808 pattern indicated**

*J1 Pin #	Symbol	I/O	J3 Pin #	Description	Logic Family
1	V <sub>cc</sub>	I	All	3.3VDC +/-5%	N/A
2	TX_Dis	I	B	Transmitter Disable	LVTTTL
3	V <sub>cc</sub>	I	All	3.3VDC +/-5%	N/A
4	TX_Dis	I	A	Transmitter Disable	LVTTTL
5					
6					
7	RX+	O	C	Receiver Data	CML
8	TX+	I	B	Transmitter Data	CML
9	RX-	O	C	Receiver Data	CML
10	TX-	I	B	Transmitter Data	CML
11					
12					
13	RX+	O	R	Receiver Data	CML
14	TX+	I	A	Transmitter Data	CML
15	RX-	O	R	Receiver Data	CML
16	TX-	I	A	Transmitter Data	CML
17					
18					
19	RX+	O	W	Receiver Data	CML
20	TX+	I	N	Transmitter Data	CML
21	RX-	O	W	Receiver Data	CML
22	TX-	I	N	Transmitter Data	CML
23					
24					
25	RX+	O	L	Receiver Data	CML
26	TX+	I	M	Transmitter Data	CML
27	RX-	O	L	Receiver Data	CML
28	TX-	I	M	Transmitter Data	CML
29					
30					
31	RX_LOS	O	C	Loss Of Signal Indicator	Open Drain CMOS
32	RX_LOS	O	R	Loss Of Signal Indicator	Open Drain CMOS
33	RX_LOS	O	W	Loss Of Signal Indicator	Open Drain CMOS
34	RX_LOS	O	L	Loss Of Signal Indicator	Open Drain CMOS
35					
36					
37	TX_Dis	I	N	Transmitter Disable	LVTTTL
38	GND	N/A	All	Signal Ground	Isolated from Case Ground
39	TX_Dis	I	M	Transmitter Disable	LVTTTL
40	GND	N/A	All	Signal Ground	Isolated from Case Ground

\*J1 center slug is isolated GND

T38F-xxxx-HW-DS - April 28, 2012 - Released

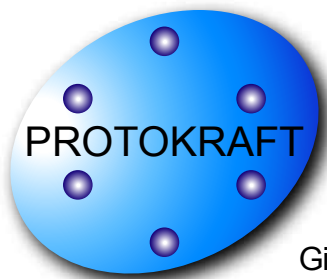

## Facilitating Secure Communications in Harsh Environments

Matrix Series MIL-DTL-38999 Optical Transceiver,  
Gigabit Ethernet, Fibre Channel, ARINC 818 Applications, Multimode, 850nm  
**J2 ELECTRICAL PIN ASSIGNMENTS - 0808 pattern indicated**

*J2 Pin #	Symbol	I/O	J3 Pin #	Description	Logic Family
1	V <sub>cc</sub>	I	All	3.3VDC +/-5%	N/A
2	TX_Dis	I	D	Transmitter Disable	LVTTTL
3	V <sub>cc</sub>	I	All	3.3VDC +/-5%	N/A
4	TX_Dis	I	S	Transmitter Disable	LVTTTL
5					
6					
7	RX+	O	E	Receiver Data	CML
8	TX+	I	D	Transmitter Data	CML
9	RX-	O	E	Receiver Data	CML
10	TX-	I	D	Transmitter Data	CML
11					
12					
13	RX+	O	F	Receiver Data	CML
14	TX+	I	S	Transmitter Data	CML
15	RX-	O	F	Receiver Data	CML
16	TX-	I	S	Transmitter Data	CML
17					
18					
19	RX+	O	H	Receiver Data	CML
20	TX+	I	V	Transmitter Data	CML
21	RX-	O	H	Receiver Data	CML
22	TX-	I	V	Transmitter Data	CML
23					
24					
25	RX+	O	J	Receiver Data	CML
26	TX+	I	K	Transmitter Data	CML
27	RX-	O	J	Receiver Data	CML
28	TX-	I	K	Transmitter Data	CML
29					
30					
31	RX_LOS	O	E	Loss Of Signal Indicator	Open Drain CMOS
32	RX_LOS	O	F	Loss Of Signal Indicator	Open Drain CMOS
33	RX_LOS	O	H	Loss Of Signal Indicator	Open Drain CMOS
34	RX_LOS	O	J	Loss Of Signal Indicator	Open Drain CMOS
35					
36					
37	TX_Dis	I	V	Transmitter Disable	LVTTTL
38	GND	N/A	All	Signal Ground	Isolated from Case Ground
39	TX_Dis	I	K	Transmitter Disable	LVTTTL
40	GND	N/A	All	Signal Ground	Isolated from Case Ground

\*J2 center slug is isolated GND

T38F-xxxx-HW-DS - April 28, 2012 - Released

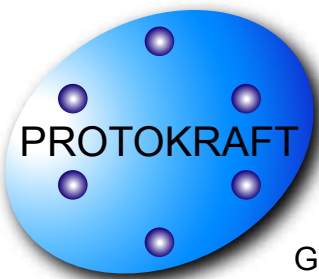

## Facilitating Secure Communications in Harsh Environments

Matrix Series MIL-DTL-38999 Optical Transceiver,  
Gigabit Ethernet, Fibre Channel, ARINC 818 Applications, Multimode, 850nm

### J1 ELECTRICAL PIN ASSIGNMENTS - 1600 pattern indicated

*J1 Pin #	Symbol	I/O	J3 Pin #	Description	Logic Family
1	V <sub>cc</sub>	I	All	3.3VDC +/-5%	N/A
2	TX_Dis	I	B	Transmitter Disable	LVTTTL
3	V <sub>cc</sub>	I	All	3.3VDC +/-5%	N/A
4	TX_Dis	I	A	Transmitter Disable	LVTTTL
5					
6					
7	TX+	I	C	Transmitter Data	CML
8	TX+	I	B	Transmitter Data	CML
9	TX-	I	C	Transmitter Data	CML
10	TX-	I	B	Transmitter Data	CML
11					
12					
13	TX+	I	R	Transmitter Data	CML
14	TX+	I	A	Transmitter Data	CML
15	TX-	I	R	Transmitter Data	CML
16	TX-	I	A	Transmitter Data	CML
17					
18					
19	TX+	I	W	Transmitter Data	CML
20	TX+	I	N	Transmitter Data	CML
21	TX-	I	W	Transmitter Data	CML
22	TX-	I	N	Transmitter Data	CML
23					
24					
25	TX+	I	L	Transmitter Data	CML
26	TX+	I	M	Transmitter Data	CML
27	TX-	I	L	Transmitter Data	CML
28	TX-	I	M	Transmitter Data	CML
29					
30					
31	TX_Dis	I	C	Transmitter Disable	LVTTTL
32	TX_Dis	I	W	Transmitter Disable	LVTTTL
33	TX_Dis	I	R	Transmitter Disable	LVTTTL
34	TX_Dis	I	L	Transmitter Disable	LVTTTL
35					
36					
37	TX_Dis	I	N	Transmitter Disable	LVTTTL
38	GND	N/A	All	Signal Ground	Isolated from Case Ground
39	TX_Dis	I	M	Transmitter Disable	LVTTTL
40	GND	N/A	All	Signal Ground	Isolated from Case Ground

\*J1 center slug is isolated GND

T38F-xxxx-HW-DS - April 28, 2012 - Released

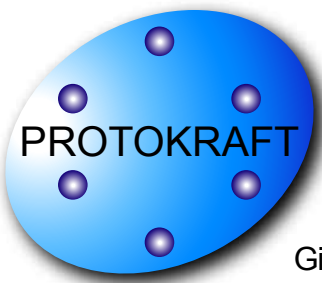

## Facilitating Secure Communications in Harsh Environments

Matrix Series MIL-DTL-38999 Optical Transceiver,  
Gigabit Ethernet, Fibre Channel, ARINC 818 Applications, Multimode, 850nm  
**J2 ELECTRICAL PIN ASSIGNMENTS - 1600 pattern indicated**

*J2 Pin #	Symbol	I/O	J3 Pin #	Description	Logic Family
1	V <sub>cc</sub>	I	All	3.3VDC +/-5%	N/A
2	TX_Dis	I	D	Transmitter Disable	LVTTTL
3	V <sub>cc</sub>	I	All	3.3VDC +/-5%	N/A
4	TX_Dis	I	S	Transmitter Disable	LVTTTL
5					
6					
7	TX+	I	E	Transmitter Data	CML
8	TX+	I	D	Transmitter Data	CML
9	TX-	I	E	Transmitter Data	CML
10	TX-	I	D	Transmitter Data	CML
11					
12					
13	TX+	I	F	Transmitter Data	CML
14	TX+	I	S	Transmitter Data	CML
15	TX-	I	F	Transmitter Data	CML
16	TX-	I	S	Transmitter Data	CML
17					
18					
19	TX+	I	H	Transmitter Data	CML
20	TX+	I	V	Transmitter Data	CML
21	TX-	I	H	Transmitter Data	CML
22	TX-	I	V	Transmitter Data	CML
23					
24					
25	TX+	I	J	Transmitter Data	CML
26	TX+	I	K	Transmitter Data	CML
27	TX-	I	J	Transmitter Data	CML
28	TX-	I	K	Transmitter Data	CML
29					
30					
31	TX_Dis	I	E	Transmitter Disable	LVTTTL
32	TX_Dis	I	H	Transmitter Disable	LVTTTL
33	TX_Dis	I	F	Transmitter Disable	LVTTTL
34	TX_Dis	I	J	Transmitter Disable	LVTTTL
35					
36					
37	TX_Dis	I	V	Transmitter Disable	LVTTTL
38	GND	N/A	All	Signal Ground	Isolated from Case Ground
39	TX_Dis	I	K	Transmitter Disable	LVTTTL
40	GND	N/A	All	Signal Ground	Isolated from Case Ground

\*J2 center slug is isolated GND

T38F-xxxx-HW-DS - April 28, 2012 - Released

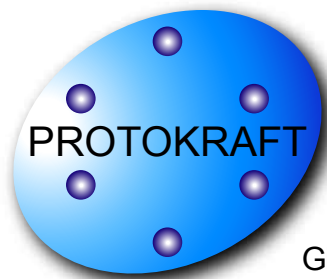

## Facilitating Secure Communications in Harsh Environments

Matrix Series MIL-DTL-38999 Optical Transceiver,  
Gigabit Ethernet, Fibre Channel, ARINC 818 Applications, Multimode, 850nm  
**J1 ELECTRICAL PIN ASSIGNMENTS - 0016 pattern indicated**

*J1 Pin #	Symbol	I/O	J3 Pin #	Description	Logic Family
1	V <sub>cc</sub>	I	All	3.3VDC +/-5%	N/A
2	RX_LOS	O	B	Loss Of Signal Indicator	Open Drain CMOS
3	V <sub>cc</sub>	I	All	3.3VDC +/-5%	N/A
4	RX_LOS	O	A	Loss Of Signal Indicator	Open Drain CMOS
5					
6					
7	RX+	O	C	Receiver Data	CML
8	RX+	O	B	Receiver Data	CML
9	RX-	O	C	Receiver Data	CML
10	RX-	O	B	Receiver Data	CML
11					
12					
13	RX+	O	R	Receiver Data	CML
14	RX+	O	A	Receiver Data	CML
15	RX-	O	R	Receiver Data	CML
16	RX-	O	A	Receiver Data	CML
17					
18					
19	RX+	O	W	Receiver Data	CML
20	RX+	O	N	Receiver Data	CML
21	RX-	O	W	Receiver Data	CML
22	RX-	O	N	Receiver Data	CML
23					
24					
25	RX+	O	L	Receiver Data	CML
26	RX+	O	M	Receiver Data	CML
27	RX-	O	L	Receiver Data	CML
28	RX-	O	M	Receiver Data	CML
29					
30					
31	RX_LOS	O	C	Loss Of Signal Indicator	Open Drain CMOS
32	RX_LOS	O	W	Loss Of Signal Indicator	Open Drain CMOS
33	RX_LOS	O	R	Loss Of Signal Indicator	Open Drain CMOS
34	RX_LOS	O	L	Loss Of Signal Indicator	Open Drain CMOS
35					
36					
37	RX_LOS	O	N	Loss Of Signal Indicator	Open Drain CMOS
38	GND	N/A	All	Signal Ground	Isolated from Case Ground
39	RX_LOS	O	M	Loss Of Signal Indicator	Open Drain CMOS
40	GND	N/A	All	Signal Ground	Isolated from Case Ground

\*J1 center slug is isolated GND

T38F-xxxx-HW-DS - April 28, 2012 - Released

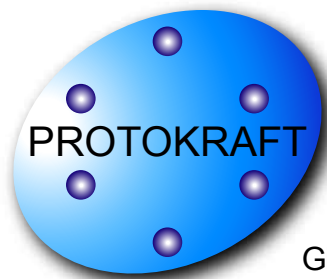

## Facilitating Secure Communications in Harsh Environments

### Matrix Series MIL-DTL-38999 Optical Transceiver, Gigabit Ethernet, Fibre Channel, ARINC 818 Applications, Multimode, 850nm **J2 ELECTRICAL PIN ASSIGNMENTS - 0016 pattern indicated**

*J2 Pin #	Symbol	I/O	J3 Pin #	Description	Logic Family
1	V <sub>cc</sub>	I	All	3.3VDC +/-5%	N/A
2	RX_LOS	O	D	Loss Of Signal Indicator	Open Drain CMOS
3	V <sub>cc</sub>	I	All	3.3VDC +/-5%	N/A
4	RX_LOS	O	S	Loss Of Signal Indicator	Open Drain CMOS
5					
6					
7	RX+	O	E	Receiver Data	CML
8	RX+	O	D	Receiver Data	CML
9	RX-	O	E	Receiver Data	CML
10	RX-	O	D	Receiver Data	CML
11					
12					
13	RX+	O	F	Receiver Data	CML
14	RX+	O	S	Receiver Data	CML
15	RX-	O	F	Receiver Data	CML
16	RX-	O	S	Receiver Data	CML
17					
18					
19	RX+	O	H	Receiver Data	CML
20	RX+	O	V	Receiver Data	CML
21	RX-	O	H	Receiver Data	CML
22	RX-	O	V	Receiver Data	CML
23					
24					
25	RX+	O	J	Receiver Data	CML
26	RX+	O	K	Receiver Data	CML
27	RX-	O	J	Receiver Data	CML
28	RX-	O	K	Receiver Data	CML
29					
30					
31	RX_LOS	O	E	Loss Of Signal Indicator	Open Drain CMOS
32	RX_LOS	O	H	Loss Of Signal Indicator	Open Drain CMOS
33	RX_LOS	O	F	Loss Of Signal Indicator	Open Drain CMOS
34	RX_LOS	O	J	Loss Of Signal Indicator	Open Drain CMOS
35					
36					
37	RX_LOS	O	V	Loss Of Signal Indicator	Open Drain CMOS
38	GND	N/A	All	Signal Ground	Isolated from Case Ground
39	RX_LOS	O	K	Loss Of Signal Indicator	Open Drain CMOS
40	GND	N/A	All	Signal Ground	Isolated from Case Ground

\*J2 center slug is isolated GND

T38F-xxxx-HW-DS - April 28, 2012 - Released

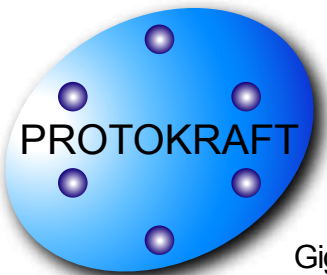

## Facilitating Secure Communications in Harsh Environments

Matrix Series MIL-DTL-38999 Optical Transceiver,  
Gigabit Ethernet, Fibre Channel, ARINC 818 Applications, Multimode, 850nm

### TRANSMITTER APPLICATION SCHEMATIC

For Xilinx Rocket I/O Interfaces

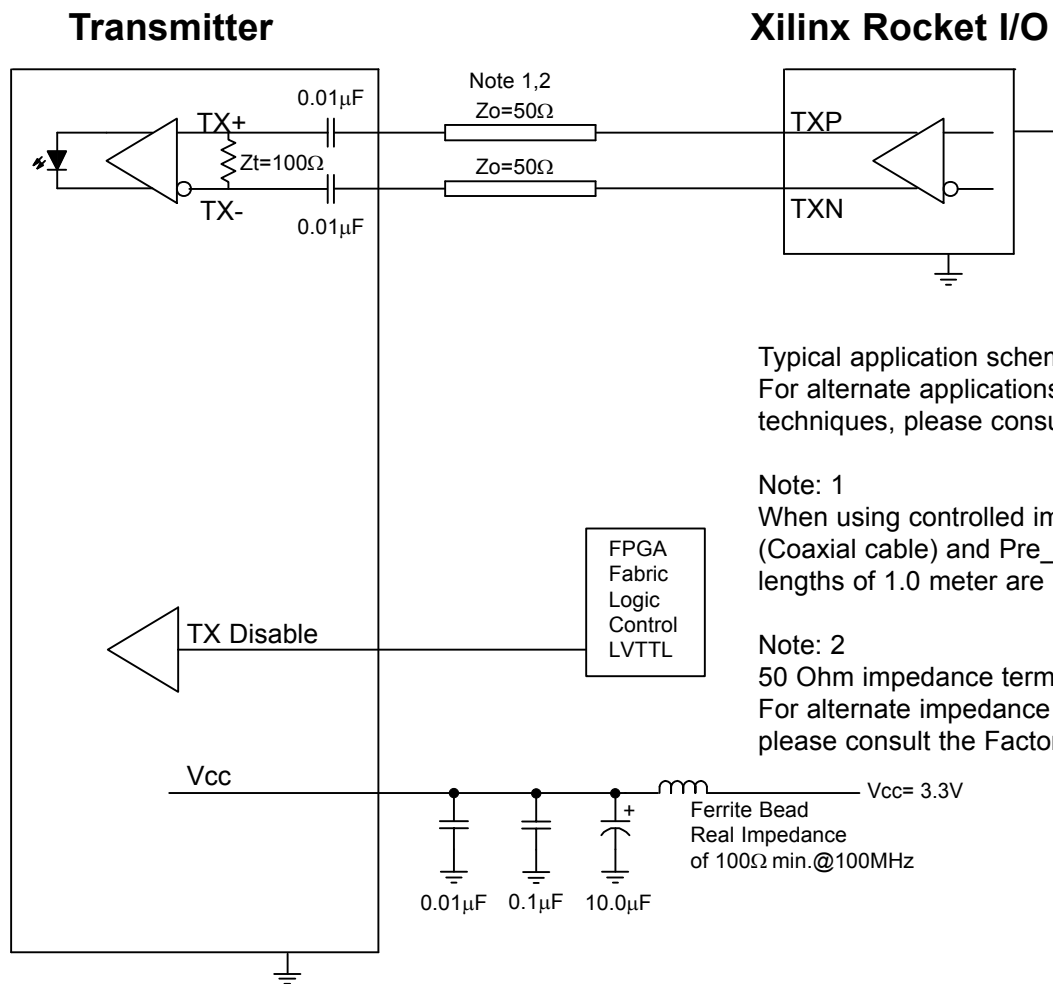

Typical application schematic shown  
For alternate applications or termination  
techniques, please consult the Factory

**Note: 1**  
When using controlled impedance cable  
(Coaxial cable) and Pre\_Emphasis,  
lengths of 1.0 meter are obtainable.

**Note: 2**  
50 Ohm impedance termination shown.  
For alternate impedance requirements,  
please consult the Factory.

**For all TX Disable Functions:**  
Logic 1: Disables Optical Output  
Logic 0: Enables Optical Output  
Internal 4.7KΩ to 10.0KΩ pullup

All Protokraft statements, technical information and recommendations related to the products herein are based upon information believed to be reliable or accurate. However, the accuracy or completeness thereof is not guaranteed, and Protokraft assumes no responsibility for any inaccuracies. The user assumes all risks and liability whatsoever in connection with the use of a product or its application. Protokraft reserves the right to change at any time, without prior or subsequent notice, the design, specifications, function, fit or form of its products described herein, including withdrawal at any time of a product offered for sale herein. Protokraft makes no representations that the products herein are free from any intellectual property claims of others. Protokraft and the Protokraft logo are trademarks of Protokraft, LLC. Other trademarks are the property of their respective holders. Contact Protokraft for prices and availability. For the most recent version of this data sheet, please go to the Protokraft website at <http://www.protokraft.com>. In case of discrepancy, the web version takes precedence over any printed literature. ©2004 Protokraft, LLC. All rights reserved.

T38F-xxxx-HW-DS - April 28, 2012 - Released

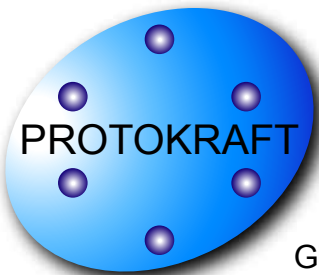

## Facilitating Secure Communications in Harsh Environments

Matrix Series MIL-DTL-38999 Optical Transceiver,  
Gigabit Ethernet, Fibre Channel, ARINC 818 Applications, Multimode, 850nm

### RECEIVER APPLICATION SCHEMATIC

For Xilinx Rocket I/O Interfaces

#### Optical Receivers

#### Xilinx Rocket I/O

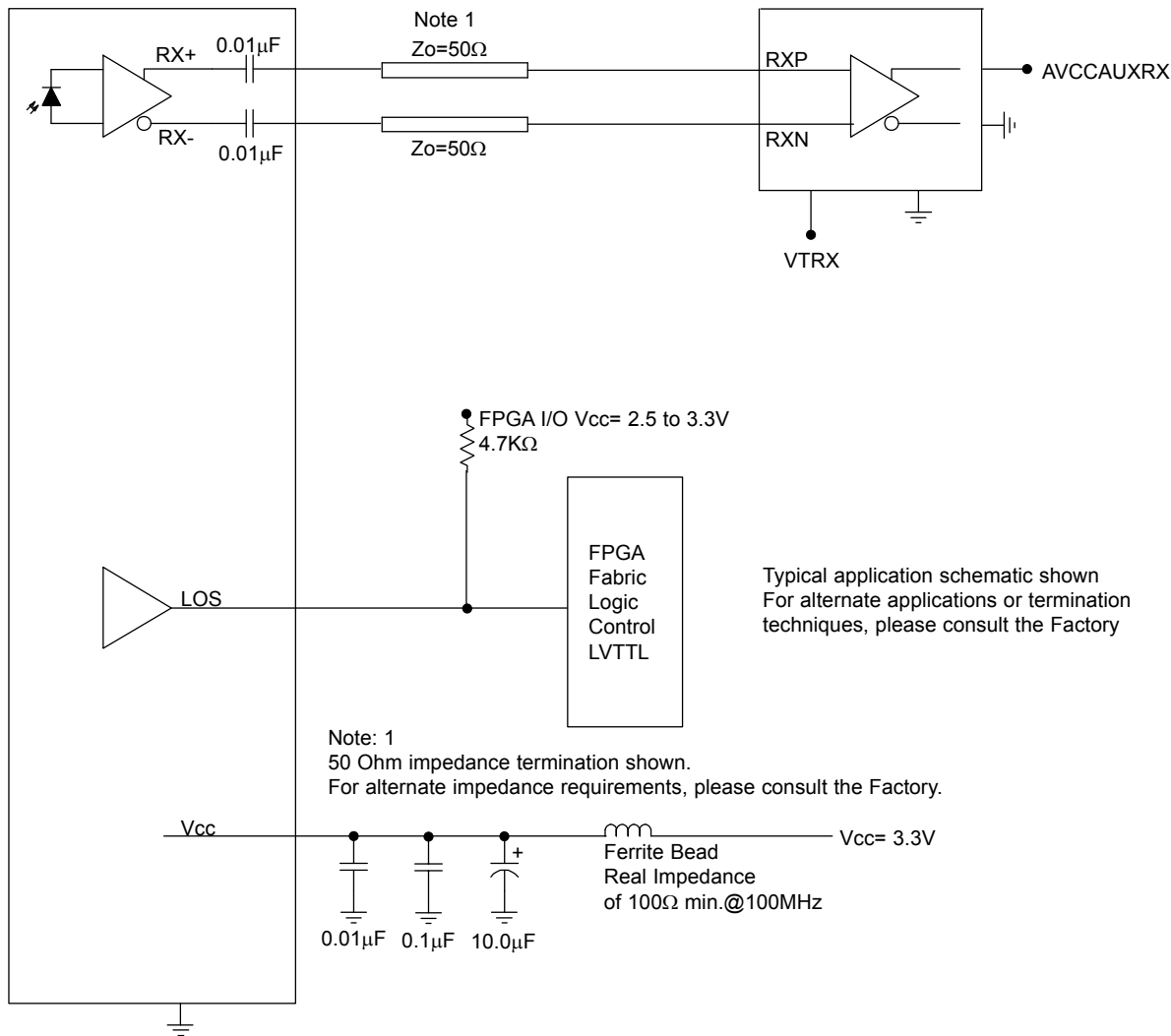

For All LOS Functions:

Satisfactory Optical Input: Logic "0" Output

Unsatisfactory Optical Input: Logic "1" Output

All Protokraft statements, technical information and recommendations related to the products herein are based upon information believed to be reliable or accurate. However, the accuracy or completeness thereof is not guaranteed, and Protokraft assumes no responsibility for any inaccuracies. The user assumes all risks and liability whatsoever in connection with the use of a product or its application. Protokraft reserves the right to change at any time, without prior or subsequent notice, the design, specifications, function, fit or form of its products described herein, including withdrawal at any time of a product offered for sale herein. Protokraft makes no representations that the products herein are free from any intellectual property claims of others. Protokraft and the Protokraft logo are trademarks of Protokraft, LLC. Other trademarks are the property of their respective holders. Contact Protokraft for prices and availability. For the most recent version of this data sheet, please go to the Protokraft website at <http://www.protokraft.com>. In case of discrepancy, the web version takes precedence over any printed literature. ©2004 Protokraft, LLC. All rights reserved.

T38F-xxxx-HW-DS - April 28, 2012 - Released

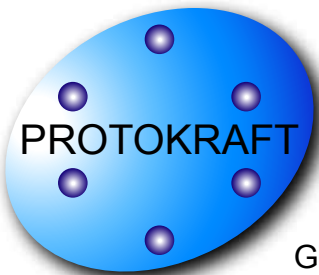

## Facilitating Secure Communications in Harsh Environments

Matrix Series MIL-DTL-38999 Optical Transceiver,  
Gigabit Ethernet, Fibre Channel, ARINC 818 Applications, Multimode, 850nm

### APPENDIX A1

#### MIL-DTL-38999 FIBER OPTIC CABLE PLUG / MIL-T-29504 RECEPTACLE TERMINI

\*See DSCC or SAE QPL for Approved Suppliers

<http://www.dsc.dla.mil/programs/qmlqpl/QPLdetail.asp?QPL=38999>

##### \*D38999 PLUG - RECEPTACLE INSERT

###### MIL-DTL-38999 CABLE PLUG

MS PLUG P/N

\*D38999/26xH21SN

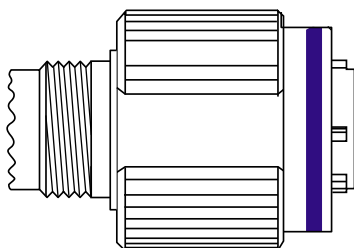

x = Service Class

##### \*FIBER OPTIC TERMINUS

###### M29504 RECEPTACLE TERMINUS

RECEPTACLE

\*M29504/05-xxxx\*\*



\*\*defined by fiber optic cable configuration

##### \*CABLE PROTECTION CAP

###### D38999/32 PLUG PROTECTION CAP

MS PLUG CAP P/N

\*D38999/32x17N

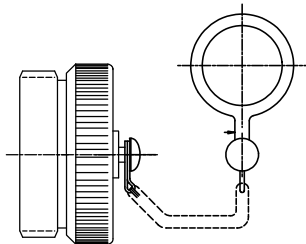

x = Service Class

T38F-xxxx-HW-DS - April 28, 2012 - Released

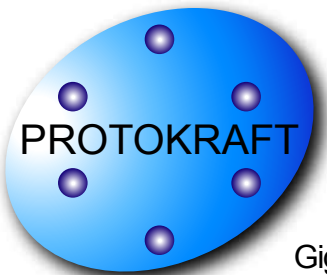

# Facilitating Secure Communications in Harsh Environments

Matrix Series MIL-DTL-38999 Optical Transceiver,  
Gigabit Ethernet, Fibre Channel, ARINC 818 Applications, Multimode, 850nm

## APPENDIX A2 PART NUMBER OPTIONS Matrix Optical Transceivers

**T38 F - 08 08 - H x x**

Product Configuration  
T38= Matrix Series

Shell Configuration  
F = Flange Mount  
J = Jam Nut

# of TX Channels  
Max = 16

# of RX Channels  
Max = 16

Shell Size Code  
H = 23-21

Shell Plating  
F = NI  
W = OD CD / NI  
Z = ZN - NI

Polarization  
(leave blank) \_ = N  
A = A  
B = B  
C = C  
D = D

Other wavelength, mounting and port count options are available.  
Please consult the Protokraft website for alternate configurations.

T38F-xxxx-HW-DS - April 28, 2012 - Released