

Matrix Series Panel Mounted Optical Transceivers



Up to 16xTX / RX or 8x full duplex optical ports



Features

- Up to 16x TX or RX functions embedded in a rugged metal housing with D38999 connector interface
- Enables simple high speed electrical interface to backplane, daughter-card or motherboard
- D38999 Size 23 Shell with Mil-T-29504/04 multimode or single mode fiber optic contacts
- High performance twinax cables for low skew, low jitter and controlled impedance
- Dual jackscrew retention enables immunity to high levels of shock and vibration
- Compact size and light weight (<8oz.) for simple mounting and installation
- Available with olive drab CD, black ZN-NI or NI surface finishes
- Suitable for any application from 125Mbps to 5.0Gbps
- Operating temperature range from -55°C to +85°C
- 3.3VDC power supply input

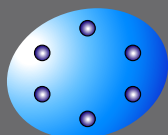

PROTOKRAFT

Facilitating Secure Communications in Harsh Environments

4545 West Stone Drive, Kingsport, TN 37660 USA

Phone: +1.423.578.7200 Fax: +1.423.578.7201

email: sales@protokraft.com

<http://www.protokraft.com>

Matrix Series Panel Mounted Optical Transceivers

Outline Drawing

Dimensions are shown as: inches [mm]

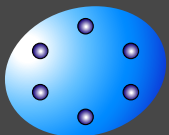
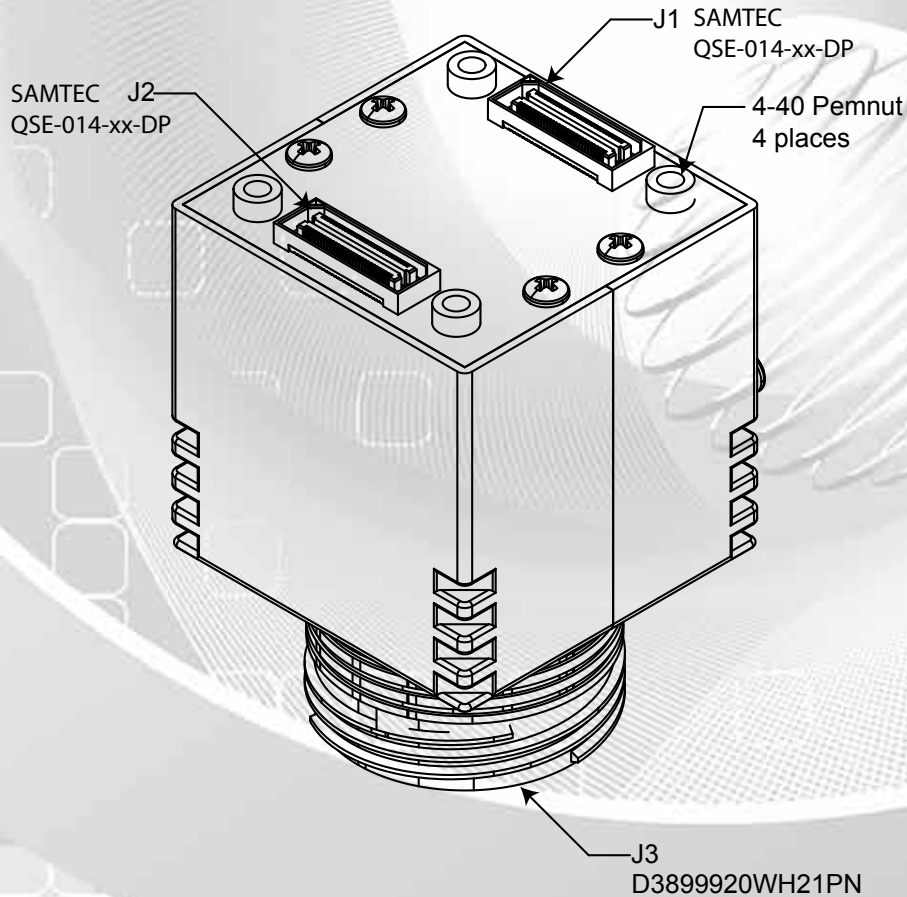
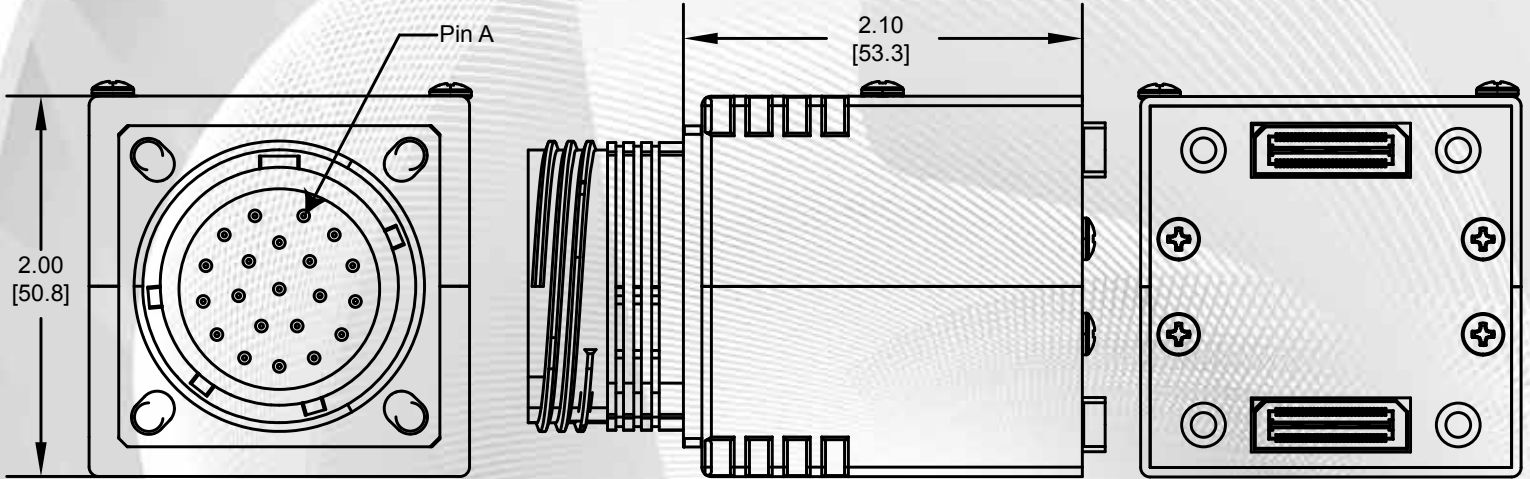

PROKRAFT

Facilitating Secure Communications in Harsh Environments

4545 West Stone Drive, Kingsport, TN 37660 USA

Phone: +1.423.578.7200 Fax: +1.423.578.7201

email: sales@protokraft.com

http://www.protokraft.com