

Direct 9 Series

ARINC 801 Compliant Optical Transceiver, DC to 1.0MHz LVTTTL Applications, Multimode, 850nm

Duplex Optical Transceiver Unit

FEATURES

- Maximum optical channel bit error rate less than 1×10^{-8}
- Operating temperature range from -40°C to $+85^{\circ}\text{C}$
- Shock and vibration resistant per RTCA / D0-160E
- Electroless nickel plating meets stringent EMI / RFI performance specifications
- D-Subminiature housings are strong, durable, corrosion resistant and light weight
- ARINC 801 compliant optical fiber connector interface
- Threaded mating connectors provide secure interface conditions in high shock and vibration environments

APPLICATIONS

Direct 9 series printed circuit board mounted optical transceivers enable high speed network communications over long distances in harsh environments.

The 9 position D-Subminiature shell provides a rugged optical interface that is compliant with ARINC 801.

The multimode optical fiber interface supports applications where copper cable link distance, bandwidth, weight or bulk make the use of twisted pair, twinax or quadax copper conductors unacceptable.



One TX & One RX Operating from DC to 1.0MHz LVTTTL

DESCRIPTION

Direct 9 series D-Subminiature optical fiber transceivers consist of optoelectronic transmitter and receiver functions integrated into a printed circuit board mounted D-Subminiature / ARINC 801 compliant receptacle connector. The optical transmitters are 850nm light emitting diodes. The transmitter input lines are driven with single ended LVTTTL signals applied to the transmitter input lines. Temperature compensated LED drivers convert the transmitter input signals to suitable LED modulation currents.

The optical receivers consist of PIN and preamplifier assemblies and limiting amplifiers. Outputs from the receivers consist of single ended LVTTTL data signals on the receiver output lines.

The electrical interface to the Direct 9 series D-Subminiature optical transceivers is a solder pin field enabling direct substitution for existing electrical 9 position D-Subminiature connectors.

Direct 9 series D-Subminiature optical fiber transceivers are vibration isolated, environmentally hardened components designed for use in harsh environment applications.

ORDERING INFORMATION

Application	Product Number
DC to 1.0MHz LVTTTL, 850nm	P24D-2S1Z-EF

P24D-2S1Z-EF-DS - September 3, 2011 - Released

Single Port Direct 9 Series D-Subminiature / ARINC 801 Optical Transceiver,
DC to 1.0MHz LVTTTL Applications, Multimode, 850nm

ABSOLUTE MAXIMUM RATINGS

Absolute maximum limits mean that no catastrophic damage will occur if the product is subjected to these ratings for short periods, provided each limiting parameter is in isolation and all other parameters have values within the performance specification. It should not be assumed that limiting values of more than one parameter can be applied to the product at the same time.

Parameter	Symbol	Minimum	Typical	Maximum	Unit
Storage Temperature	T_s	-55		+100	°C
Supply Voltage	V_{CC}	-0.5		+4.5	V
Data Input Voltage	V_I	-0.5		V_{CC}	V
Differential Input Voltage (p-p)	V_D			2.0	V
RX Output Current	I_O			50	mA

RECOMMENDED OPERATING CONDITIONS

Parameter	Symbol	Minimum	Typical	Maximum	Unit
Operating Temperature	T_A	-40		+85	°C
Power Supply Voltage	V_{CC}	+3.135		+3.465	V
TX Common Mode Voltage	V_{CM}		2.0		V
TX Differential Input Voltage (p-p)	V_D	0.35		1.25	V
Power Supply Noise (p-p)	N_P			200	mV

SPECIFICATIONS COMPLIANCE

Requirement	Feature	Condition	Notes
RTCA / D0-160E	ESD	Class II	2200V
RTCA / D0-160E	Vibration	3.8g ² /Hz	43G rms
RTCA / D0-160E	Shock	40.0g	6-9mS
RTCA / D0-160E	Flame Resistance	Method 1012	30 Seconds
RTCA / D0-160E	Damp Heat	10 Cycles	24 Hours
Arinc 801	Mating Durability	500 Cycles	<0.5dB Change
FDA / CDRH / IEC-825-1	Eye Safety	Class 1	No Safety Interlocks Required

MATERIALS

Item	Detail	Notes
Shell	Steel Alloy	
Shell Plating	Electroless Nickel	
Insert	Thermoplastic	
Solder Pins	Brass	
Solder Pin Plating	Gold	
Alignment Sleeves	Composite Polymer	
Printed Circuits	Polyimide / FR-4	

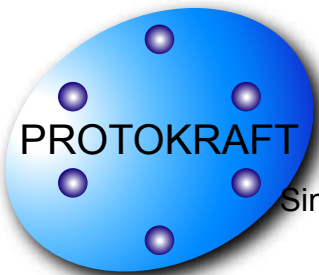

Facilitating Secure Communications in Harsh Environments

Single Port Direct 9 Series D-Subminiature / ARINC 801 Optical Transceiver,
DC to 1.0MHz LVTTTL Applications, Multimode, 850nm

TRANSMITTERS T_A = Operating Temperature Range, V_{CC} = 3.135V to 3.465V

Parameter	Symbol	Minimum	Typical	Maximum	Unit
Optical Output Power ¹	P_o	-15.0		-8.0	dBm
Optical Output Wavelength	λ_{OUT}	830	850	860	nM
Extinction Ratio	ER	10.0			dB
Optical Rise / Fall Time (10% to 90%)	$t_{R,F}$	0.6		3.0	nS

1. BER=1x10⁻⁹ @ 1.0 Mbps @ 50% Duty Factor, tested with 62.5/125 μ multimode fi ber

RECEIVERS T_A = Operating Temperature Range, V_{CC} = 3.135V to 3.465V

Parameter	Symbol	Minimum	Typical	Maximum	Unit
Optical Sensitivity ¹	P_i	-26.0		-8.0	dBm
Optical Wavelength	λ_{IN}	700		900	nM

1. BER=1x10⁻⁹ @ 1.0 Mbps @ 50% Duty Factor, tested with 62.5/125 μ multimode fi ber

SUPPLY CURRENT T_A = Operating Temperature Range, V_{CC} = 3.135V to 3.465V

Parameter	Symbol	Minimum	Typical	Maximum	Unit
Supply Current per Port	I_{CCT}		125	165	mA

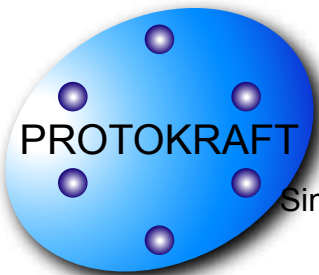

Facilitating Secure Communications in Harsh Environments

Single Port Direct 9 Series D-Subminiature / ARINC 801 Optical Transceiver,
DC to 1.0MHz LVTTTL Applications, Multimode, 850nm

OUTLINE DRAWING

Dimensions are shown as: inches (mm)

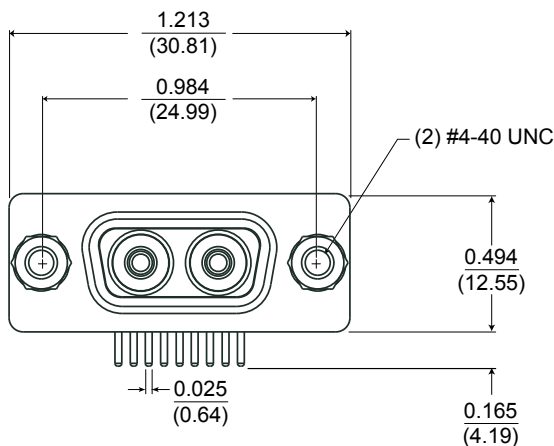

Recommended PCB Layout Top View - Component Side

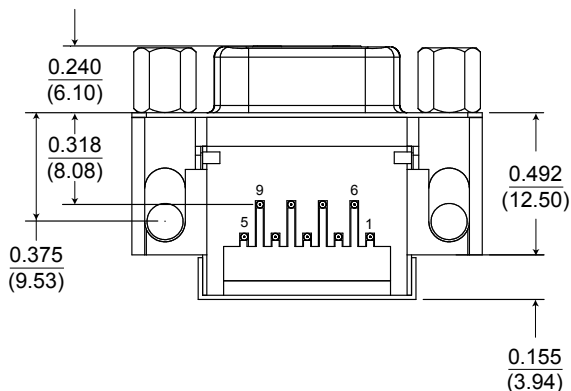
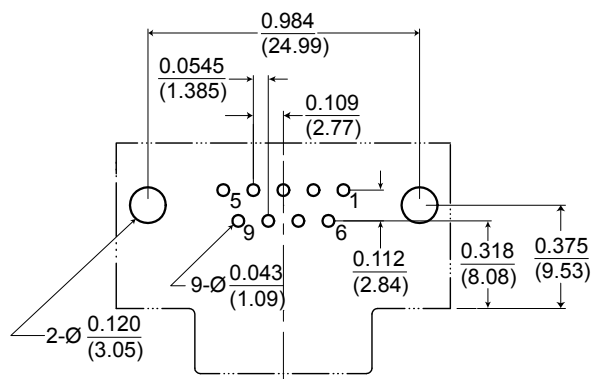

Aqueous washing is permitted with the protective covers in place.
If necessary, after washing, clean the optical barrels with lint free swabs and Isopropyl alcohol
The transceivers are conformally coated but after aqueous washing the units should be baked @
85°C for 1.0 hour to eliminate any retained moisture.

P24D-2S1Z-EF-DS - September 3, 2011 - Released

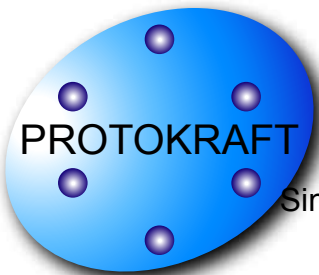

Facilitating Secure Communications in Harsh Environments

Single Port Direct 9 Series D-Subminiature / ARINC 801 Optical Transceiver,
DC to 1.0MHz LVTTTL Applications, Multimode, 850nm

ELECTRICAL PIN ASSIGNMENTS

D-Subminiature Shell Size 09

Pin Number	Symbol	Description	Logic Family
1	RX	Receiver Data - Output	LVTTTL
2	GND	Ground	N/A
3	GND	Ground	N/A
4	GND	Ground	N/A
5	TX	Transmitter Data - Input	LVTTTL
6	V _{cc}	Power Supply	N/A
7	GND	Ground	N/A
8	GND	Ground	N/A
9	GND	Ground	N/A

INSERT ARRANGEMENT

D-Subminiature Shell Size 09

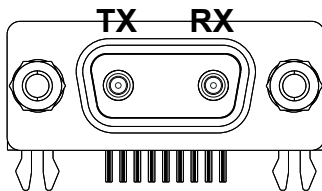

Front face of the
transceiver socket
insert shown!

Mating cable plug
interface opposite.

P24D-2S1Z-EF-DS - September 3, 2011 - Released

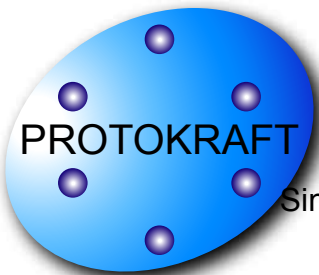



Facilitating Secure Communications in Harsh Environments

Single Port Direct 9 Series D-Subminiature / ARINC 801 Optical Transceiver,
DC to 1.0MHz LVTTTL Applications, Multimode, 850nm

APPLICATION SCHEMATIC

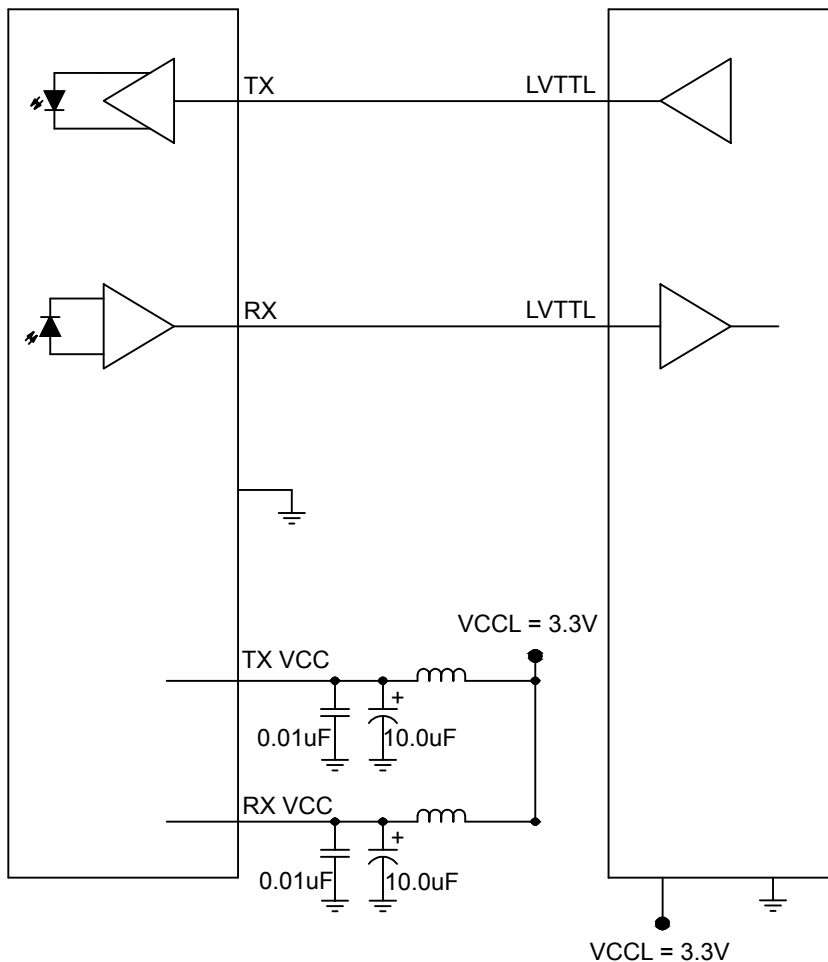
OPTICAL TRANSCEIVER INTERFACE LOGIC



 Ferrite Beads
 Real Impedance
 of 100Ohms min.
 @ 100MHz

All Protokraft statements, technical information and recommendations related to the products herein are based upon information believed to be reliable or accurate. However, the accuracy or completeness thereof is not guaranteed, and Protokraft assumes no responsibility for any inaccuracies. The user assumes all risks and liability whatsoever in connection with the use of a product or its application. Protokraft reserves the right to change at any time, without prior or subsequent notice, the design, specifications, function, fit or form of its products described herein, including withdrawal at any time of a product offered for sale herein. Protokraft makes no representations that the products herein are free from any intellectual property claims of others. Protokraft and the Protokraft logo are trademarks of Protokraft, LLC. Other trademarks are the property of their respective holders. Contact Protokraft for prices and availability. For the most recent version of this data sheet, please go to the Protokraft website at <http://www.protokraft.com>. In case of discrepancy, the web version takes precedence over any printed literature. ©2004 Protokraft, LLC. All rights reserved.

P24D-2S1Z-EF-DS - September 3, 2011 - Released

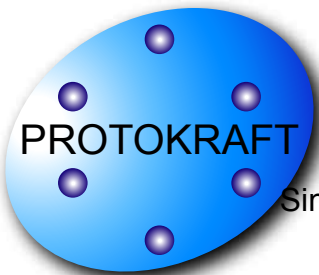

Facilitating Secure Communications in Harsh Environments

Single Port Direct 9 Series D-Subminiature / ARINC 801 Optical Transceiver,
DC to 1.0MHz LVTTTL Applications, Multimode, 850nm

APPENDIX A1

DIRECT 9 FIBER OPTIC CABLE PLUG / ARINC 801 PIN TERMINI

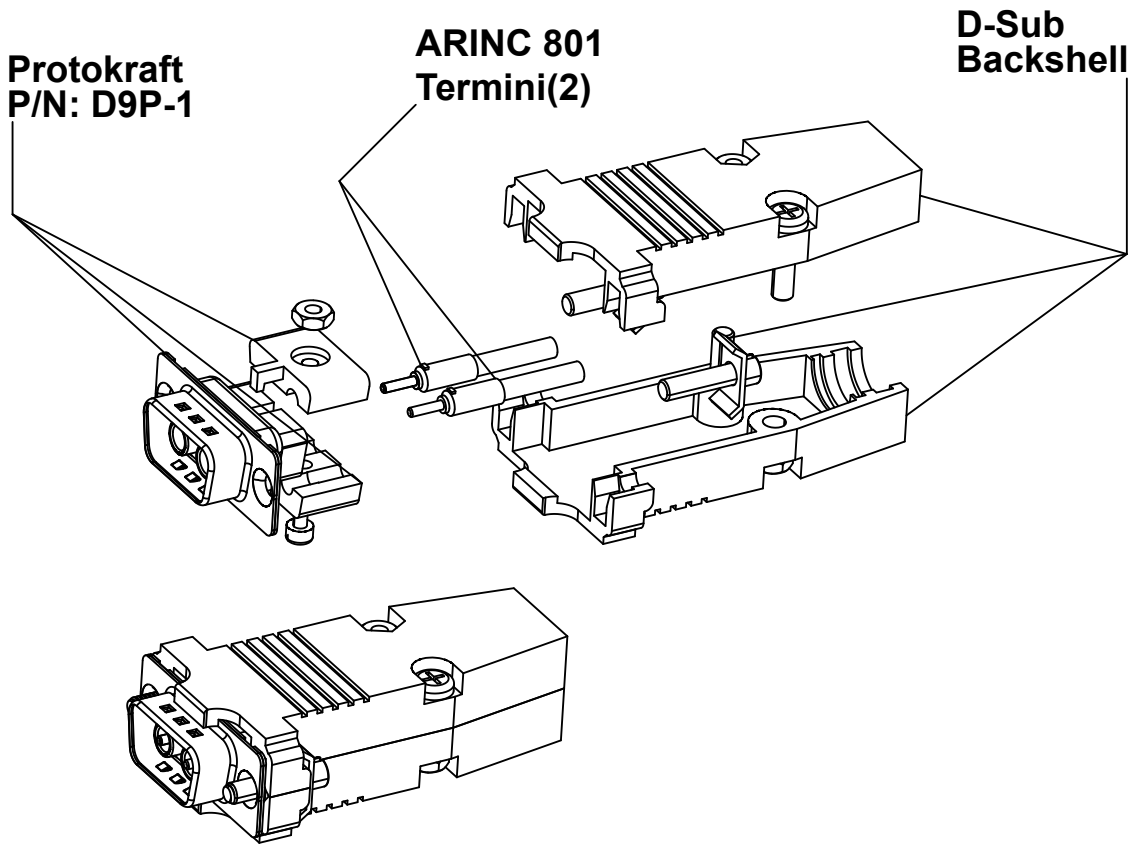

P24D-2S1Z-EF-DS - September 3, 2011 - Released

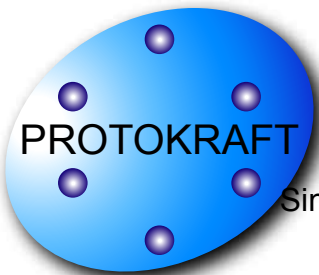

Facilitating Secure Communications in Harsh Environments

Single Port Direct 9 Series D-Subminiature / ARINC 801 Optical Transceiver,
DC to 1.0MHz LVTTTL Applications, Multimode, 850nm

APPENDIX A2

Direct 9 Fiber Optic D-Subminiature Cable Plug Insert

Dimensions are shown as: inches [mm]

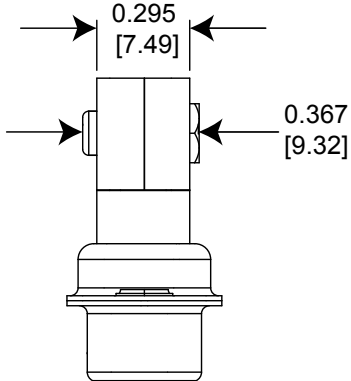
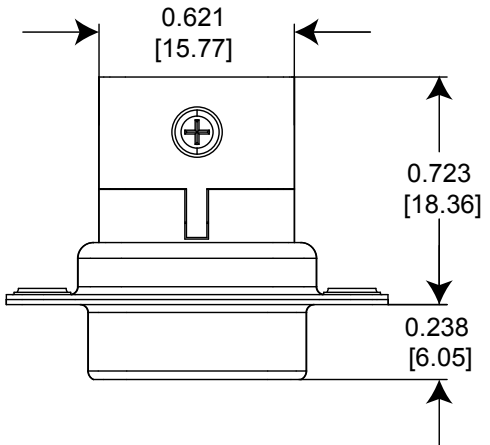
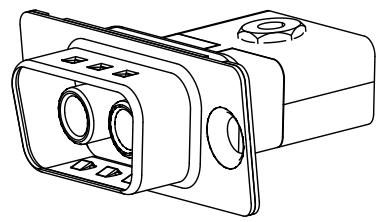
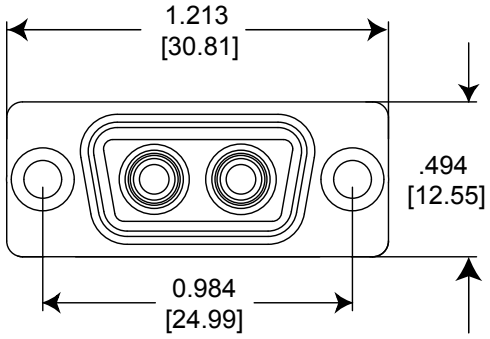

Protokraft Direct 9 Fiber Optic Cable Plug Part Number: D9P-1
See Appendix A3 for test cable options

P24D-2S1Z-EF-DS - September 3, 2011 - Released

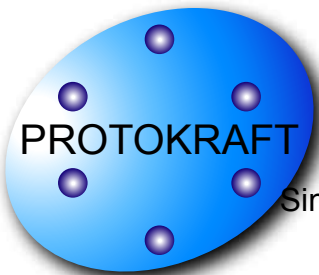

Facilitating Secure Communications in Harsh Environments

Single Port Direct 9 Series D-Subminiature / ARINC 801 Optical Transceiver,
DC to 1.0MHz LVTTTL Applications, Multimode, 850nm

APPENDIX A3

Direct 9 Fiber Optic D-Subminiature Test Cable Options

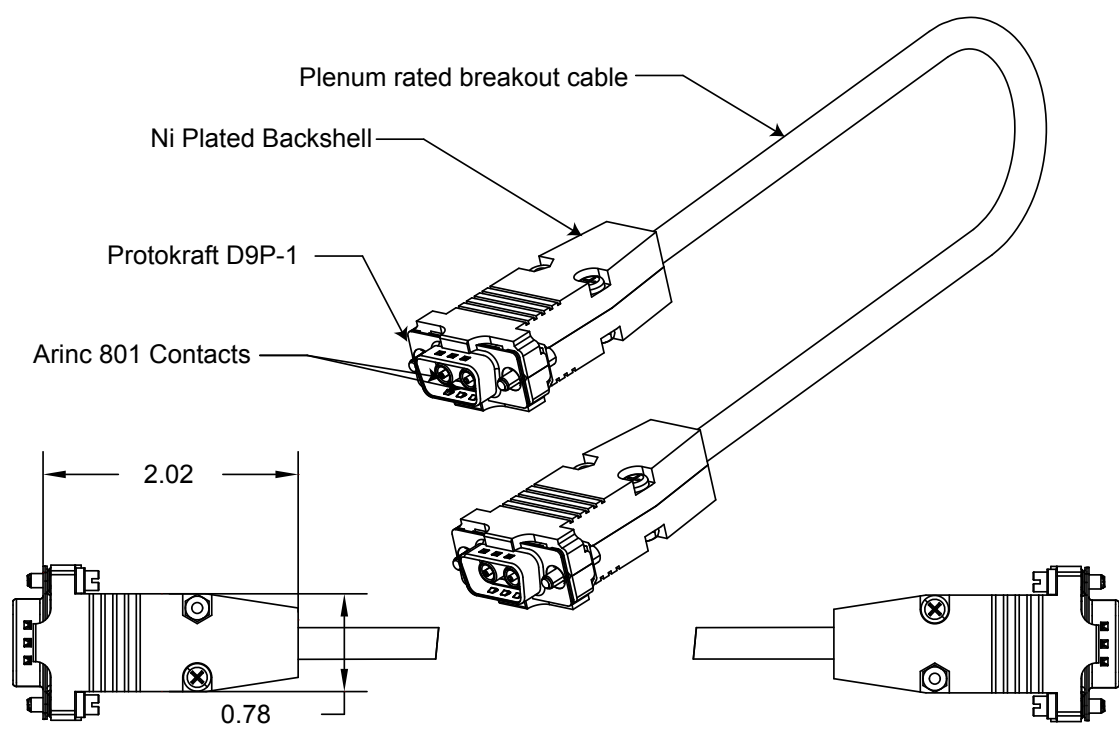

P24C-0121 -1 Shown



- P24C-XX XX- X
- 01-99 Meters
 - 1 = 50µm
 - 2 = 62.5µm
 - 1 = D9P-1 STRAIGHT
 - 2 = D9P-1 RIGHT ANGLE
 - 1 = D9P-1 STRAIGHT
 - 2 = D9P-1 RIGHT ANGLE
 - 3 = ST
 - 4 = LC
 - 5 = FC

P24D-2S1Z-EF-DS - September 3, 2011 - Released